

Cellular Development Platform

All-in-one Hardware and Open Source Development Environment



Benefits

- Linux-based open source software
- Proven hardware for the development and deployment of custom applications
- Cost-effective alternative to custom manufacturing
- Comprehensive service and developer support

The Multi-Tech Cellular Development Platform with CoreCDP™ is a complete hardware solution and a complete Linux environment in one. Nowhere else will you find an open Linux development environment and a fully certified hardware offering that includes multiple interfaces and internal peripherals in one application-ready end user solution.

Applications that require device networking capability can now be embedded directly onto select Multi-Tech hardware. The Cellular Development Platform brings together a cellular hardware development kit and Multi-Tech's CoreCDP, a distribution version of the Linux operating system and complete Linux build environment, to create custom applications in a very short period of time. The Multi-Tech Cellular Development Platform provides a flexible, quick and cost-effective way to bring your solution to market.

Development Hardware

- Application-ready hardware platform
- Includes GPS and cellular modem
- Multiple interfaces available (serial, USB, Ethernet)
- 36-pin GPIO interface
- FCC, IC, UL, PTCRB and R&TTE certified

CoreCDP™ Software

- Custom Linux distribution
- Provides complete Linux build environment
- Cross-compile thousands of open source software packages
- Create custom applications in a short period of time

Support

- Advanced developer support available
- Established developer community available at www.multitech.net
- Two Year Warranty

Deployment Models

- Cellular-only and cellular/GPS models available
- Standard and customized deployment models available
- FCC, IC, UL, PTCRB and R&TTE certified

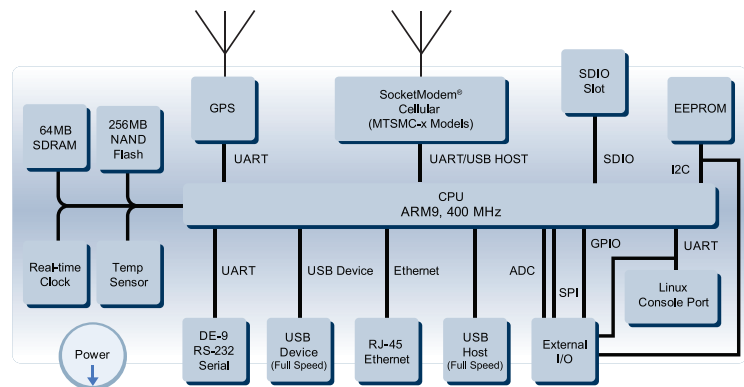

Highlights

Custom Application Development and Deployment. The Cellular Development Platform offers customers the opportunity to develop and deploy custom applications on the same product platform. Developer kits include all the hardware, cables and accessories required to develop unique applications. Once complete, deployment models are available for the sale and distribution of the solution within a proven and approved hardware platform.

Linux-Based Open Source. The Cellular Development Platform uses the OpenEmbedded framework as the base to provide a custom Linux distribution, known as CoreCDP. This allows developers to cross-compile thousands of open source software packages and to create custom applications in a very short period of time. In many cases, existing applications can easily be run with little or no modification.

Carrier Approved. All Cellular Development Platform developer kits and deployment models are PTCRB approved, relieving customers the burden and expense of obtaining these approvals independently. This also provides a faster time-to-market and improved return on investment.

Multiple Interface Options. The Cellular Development Platform provides the broadest range of interface options, including serial, USB host, and Ethernet, giving customers seamless connectivity to their applications.

GPIO. The 36-pin general purpose input/output connection, which includes SPI, I2C, serial, ADC, and GPS connections, provides multiple ways of interfacing with any application.

Proof of Concept. Customers planning their own internal custom developments can use the Cellular Development Platform to create beta units and prototypes for use in voice of customer and proof of concept activities. These models can be generated quickly and with little additional expense. The input from these activities can improve the feature set of the customer's final product.

Comprehensive Service and Support

Standard Support. The Multi-Tech Cellular Development Platform includes a two-year product warranty on the hardware platform. This includes technical support, via the Multi-Tech online support portal, to assist with troubleshooting and basic hardware configurations.

Developer Community and Support. To support software developers who are using the Cellular Development Platform, Multi-Tech focuses on building better tools for collaborative software development using Multi-Tech products. This is an open environment where software developers can ask and respond to development-related questions regarding Multi-Tech products and access a variety of resources, including product documentation, application development examples, technical articles and much more.

You can also participate in developer forums on www.multitech.net to find and share ideas and tips. Moderated by Multi-Tech engineering professionals and the developer community, these forums address a wide variety of development topics to support your projects.

Advanced Developer Support. For developers needing dedicated support, Multi-Tech offers a fee-based support option available in 5-hour and 25-hour increments. Advanced Developer Support provides assistance with software issues, the porting of or cross-compiling of applications, use of peripherals and much more.

Hardware Specifications

Processor & Memory

400 MHz ARM9 CPU
256MB NAND flash
64MB SDRAM
2GB industrial grade SD Flash Card (included)

Internal Peripherals

RTC (Real Time Clock)
Dedicated GPS receiver
Cellular modem
Debug 3 pin serial console port
Temperature sensor

Connections

LAN: RJ-45, 10/100BaseT
RS-232 Data: DB-9 female, 921.6K bps max serial speed
GSM/GPS Antenna: 50 ohm SMA female
Power: 2.5mm miniature screw
SIM: Standard 1.8V & 3V SIM receptacle
USB Host: USB 2.0 Full Speed (12 Mbps) Host connector
USB Device: USB 2.0 Full Speed (12 Mbps) mini-B device connector
GPIO: 36-pin molex connection
SD Memory Flash Card: SD memory card slot

GPIO Functions:*

Pins 1 - 9: General Purpose Input
Pins 10 - 14: Analog Input
Pins 15 - 24: General Purpose Output
Pins 25 - 29: SPI
Pins 30 - 31: Debug
Pin 32: GPS PPS
Pins 33 - 34: I2C
Pin 35: No Connect
Pin 36: Ground (SPI, I2C, Serial)

* For more specifications on GPIO functionality, visit www.multitech.net

Interfaces

General Purpose LEDs: Power, Cellular Link Status, Ethernet Link, & Speed
Programmable LEDs: 5 user-defined, application-specific LEDs

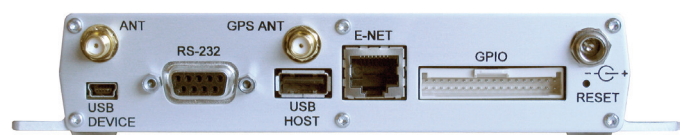

Hardware Specifications (continued)

Short Message Services - SMS

Text & PDU, Point-to-Point (MO/MT), cell broadcast

GPS

Position: 2.5 meters

Aquisition: Hot start 1 second; cold start 29 seconds avg.

Sensitivity: Tracking -161 dBm

Protocol: NMEA-0183 V3.01, GGA, GLL, GSA, GSV, RMC, VTG

Power Requirements

9 to 32VDC

Physical Dimensions (L x W x H)

2.8" x 7.0" x 1.2"
(7.1 cm x 17.8 cm x 3.0 cm)

Weight

11.5 ounces (326 grams)

CoreCDP Software Specifications

Linux Kernel 2.6.32.3

Utilizes OpenEmbedded framework

Tested with the following Linux OS:

Ubuntu 9.10 & 10.04

Fedora Core 12

OpenSUSE 12.1

Drivers to support all peripherals included on the platform hardware

Programming Languages: Python, Java (JamVM), Perl, Ruby, C/C++, PHP

Networking: PPP, iptables

Web Server: lighttpd

Remote shell: SSH

Database: sqlite3

Network file system: samba

Security: OpenSSL

Specifications	MTCDP-H4	MTCDP-EV2	MTCDP-E1	MTCDP-G2
Performance	HSPA	CDMA2000 1xRTT	EDGE: E-GPRS Class 12 GPRS: Class 10	GPRS Class 10
Band, Frequency	HSUPA/HSDPA/UMTS Triple-band: 2100/1900/850 MHz with Rx diversity	Dual-band 800/1900 MHz CDMA; 800 MHz & 800/1900 MHz with R-UIM support	Quad-band GSM/GPRS/EDGE 850/900/1800/1900 MHz	Quad-band GSM 850/900/1800/1900 MHz
Packet Data	HSDPA data service of up to 7.2 Mbps HSUPA data service of up to 5.76 Mbps	Peak download 3.1 Mbps, peak upload 1.8 Mbps	EDGE: E-GPRS Up to 240K bps, coding scheme MCS1-9, mobile station Class B, LLC layer, 4 time slots GPRS: Full PBCCH support, coding scheme 1-4, mobile station Class B	Up to 85.6K bps, coding schemes CS1 to CS4
Environmental				
Operating Temperature*	-22° to 140° F (-30° to +60° C)*	-40° to 167° F (-40° to +75° C)*	-31° to 167° F (-35° to +75° C)*	-40° to 185° F (-40° to +85° C)*
	* UL Listed @ 104° F (40° C), limited by power supply. UL Certification does not apply or extend to an ambient above 104° F (40° C) and has not been evaluated by UL for ambient greater than 104° F (40° C).			
Storage Temperature	-40° to +185° F (-40° to +85° C)			
Humidity	20% to 90% RH, noncondensing			
Certifications				
EMC Compliance	FCC Part 15, EN55022, EN55024	FCC Part 15	FCC Part 15, EN55022, EN55024	
Radio Compliance	FCC Part 22, 24, RSS132,133, EN301 489-1, EN489-3 (-GP only), EN301 489-7, EN301 511, AS/ACIF S042.1, S042.3	FCC Part 22, 24, RSS132, 133	FCC Part 22, 24, RSS132,133, EN301 489-1, EN489-3 (-GP only), EN301 489-7, EN301 511, AS/ACIF S042.1, S042.3	
Safety	UL60950-1, cUL60950-1, IEC60950-1	UL60950-1, cUL60950-1, IEC60950-1	UL60950-1, cUL60950-1, IEC60950-1	UL60950-1, cUL60950-1, IEC60950-1, AS/NZS60950-1
Network	PTCRB	CDG 1&2	PTCRB	

Ordering Information

Developer Kits

Developer kits include: Modem with GPS receiver, universal power supply, GSM/GPS antenna, GPIO cable, serial debug cable, Ethernet cable, RS-232 cable, compact flash, USB cables, DVD, and screwdriver.

Product	Description	Region
MTCDP-H4-GP-P1-DK-1.0	3G, HSPA (Generic) Developer Kit	Europe
MTCDP-H4-GP-P2-DK-1.0	3G, HSPA (AT&T) Developer Kit	USA
MTCDP-EV2-GP-N2-DK-1.0	3G, EVDO (Sprint) Developer Kit	USA
MTCDP-EV2-GP-N3-DK-1.0	3G, EVDO (Verizon Wireless) Developer Kit	USA
MTCDP-EV2-GP-N16-DK-1.0	3G, EVDO (Aeris Communications) Developer Kit	USA
MTCDP-E1-GP-DK-1.0	2.5G EDGE Developer Kit	Global
MTCDP-G2-GP-DK-1.0	2G, GPRS Developer Kit	Global

Deployment Models (includes GPS receiver)*

Deployment models are modem only. All accessories are sold separately.

Product	Description	Region
MTCDP-H4-GP-P1-1.0	3G, HSPA (Generic) Deployment Model	Europe
MTCDP-H4-GP-P2-1.0	3G, HSPA (AT&T) Deployment Model	USA
MTCDP-EV2-GP-N2-1.0	3G, EVDO (Sprint) Deployment Model	USA
MTCDP-EV2-GP-N3-1.0	3G, EVDO (Verizon Wireless) Deployment Model	USA
MTCDP-EV2-GP-N16-1.0	3G, EVDO (Aeris Communications) Deployment Model	USA
MTCDP-E1-GP-1.0	2.5G EDGE Deployment Model	Global
MTCDP-G2-GP-1.0	2G, GPRS Deployment Model	Global

Deployment Models*

Deployment models are modem only. All accessories are sold separately.

Product	Description	Region
MTCDP-H4-P1-1.0	3G, HSPA (Generic) Deployment Model	Europe
MTCDP-H4-P2-1.0	3G, HSPA (AT&T) Deployment Model	USA
MTCDP-EV2-N2-1.0	3G, EVDO (Sprint) Deployment Model	USA
MTCDP-EV2-N3-1.0	3G, EVDO (Verizon Wireless) Deployment Model	USA
MTCDP-EV2-N16-1.0	3G, EVDO (Aeris Communications) Deployment Model	USA
MTCDP-E1-1.0	2.5G EDGE Deployment Model	Global
MTCDP-G2-1.0	2G, GPRS Deployment Model	Global

Developer Support

For developers needing dedicated support, Multi-Tech offers a fee-based support option. Advanced Developer Support provides assistance with software issues, the porting of or cross-compiling of applications, use of peripherals, and much more.

Product	Description	Region
CDPS-5	Developer Support - 5 hours	Global
CDPS-25	Developer Support - 25 hours	Global

Accessories

CA-CDP-GPIO	36-pin, General Purpose Input/Output Cable (open ended)
PS-9VCB-LBC-U-Global	100 - 240V 9V-1.7A changeable blade power supply with three interchangeable blades (U.S., Euro, UK)
ANGSM-GPS-1MM	GSM/GPS Combination Antenna, 9.8 feet (3 meters)
CA-CDP-DEBUG	3-Pin, Serial Debug Cable, 6 feet (1.8 meters)
CA9-9-D	RS-232 Cable, DB9F-DB9M, 6 feet (1.8 meters)
CA-RJ-45	RJ45 (CAT5E, 10/100 Mbps) Cable, 6 feet (1.8 meters)
CA-USB	USB A/B Cable, 4.9 feet (1.5 meters)
CA-USB-A-MINI-B	USB A-to-Mini-B Cable, 3.9 feet (1.2 meters)

* Custom deployment options available. Contact your Multi-Tech Systems representative for details.

Produced in the US of US and non-US components.

Features and specifications are subject to change without notice.

Trademarks / Registered Trademarks: SocketModem, CoreCDP, Multi-Tech, and the Multi-Tech logo: Multi-Tech Systems, Inc. / All other products and technologies are the trademarks or registered trademarks of their respective holders.

World Headquarters

Tel: (763) 785-3500
(800) 328-9717

www.multitech.com

EMEA Headquarters

Multi-Tech Systems (EMEA)
United Kingdom

Tel: +(44) 118-959 7774